

Application Notes

Description: Methanol-Isopropyl Alcohol (IPA)-Water Separation System

Process Flow Diagram

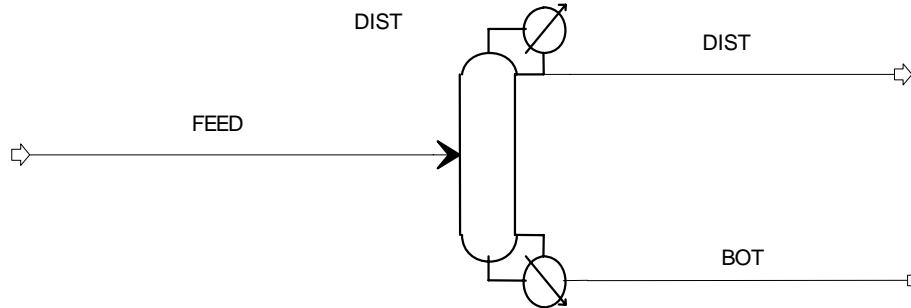

Process Description

Isopropyl Alcohol (IPA), water and methanol mixture is fed to first column and methanol with 99.5 % (wt) purity, is removed in this column. IPA-water azeotrope is drawn as bottom product. The typical feed composition is as follows

IPA	: 70-55 % (wt)
Water	: 10-15 % (wt)
Methanol	: 15-20% (wt)

Design basis : 90-95 % Recovery of methanol

Operating Conditions

Operating Pressure

Column is operating under atmospheric pressure

Column Internals :

Structured packing for the column

